



S1500-Dewatering Pump

MIGHTY INDUSTRIAL STRENGTH PUMPS

- Stainless Steel Hardened Impeller •
- High Efficiency • Silicon Carbide Mechanical Seal •

Features

1500 model pumps are equipped with a stainless steel seal housing and a stainless steel cartridge type seal with solid silicon carbide seal faces. This state of the art system can withstand extremely high pressure and utilizes anti-vibration bellows to prevent the seal faces from separating even under the most extreme operating conditions. The mechanical seals run in an oil-filled chamber reducing the chance of overheating and failure.

Performance/Specifications

Maximum Flow:	HV: 1100 US gpm	HH: 400 US gpm
Maximum Head:	HV: 120 ft	HH: 230 ft
Horsepower:	HV: 15	HH: 15
Voltage:	HV: 230/460/575	HH: 230/460/575
Discharge:	HV: 4"	HH: 6"
Weight:	HV: 220 lbs	HH: 220 lbs
Height:	HV: 33 1/8"	HH: 33 1/8"
Diameter:	HV: 16 1/8"	HH: 16 1/8"
MSHA Des.:	HV: P60CEM	HH: P60CEM

S1500 Performance Curve

(P60CEM - MSHA Explosion-Proof Pump Model)

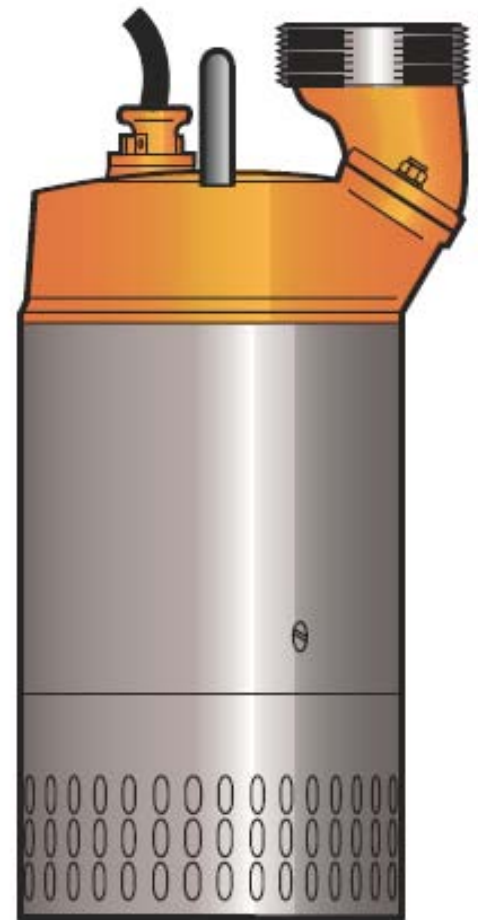
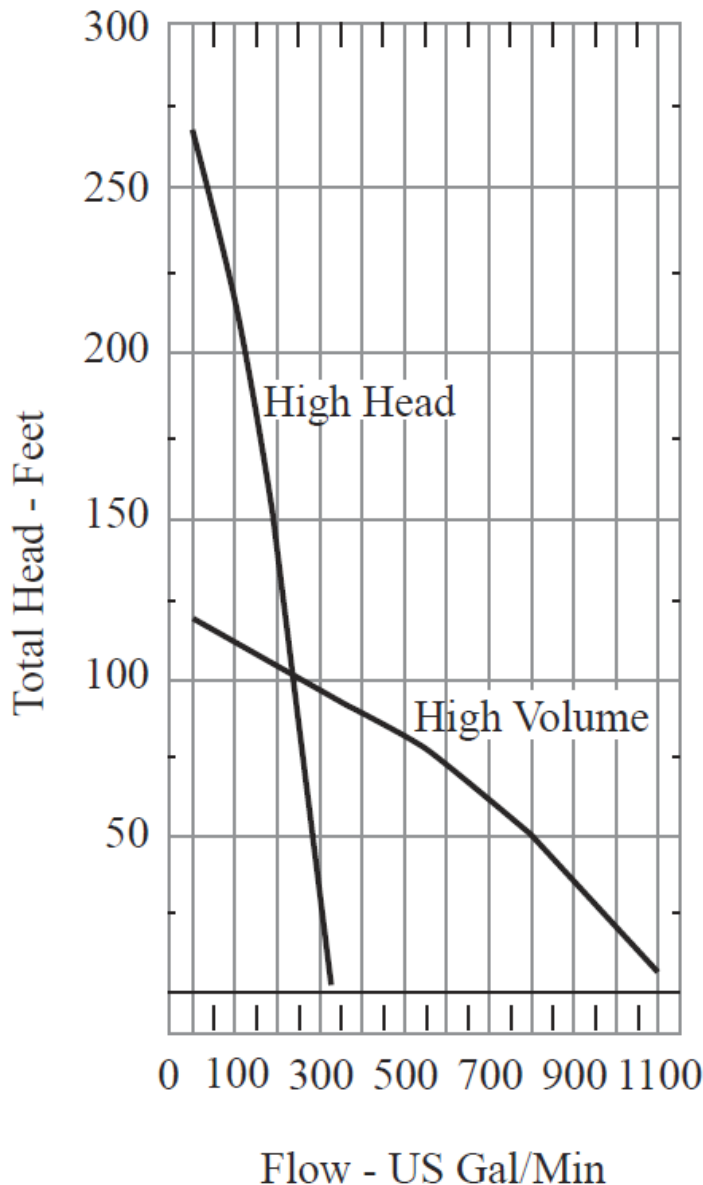

Phone: 1-877-898-3494
 Fax: 1-866-424-0953
 Email: sales@mightypumps.com
 www.mightypumps.com

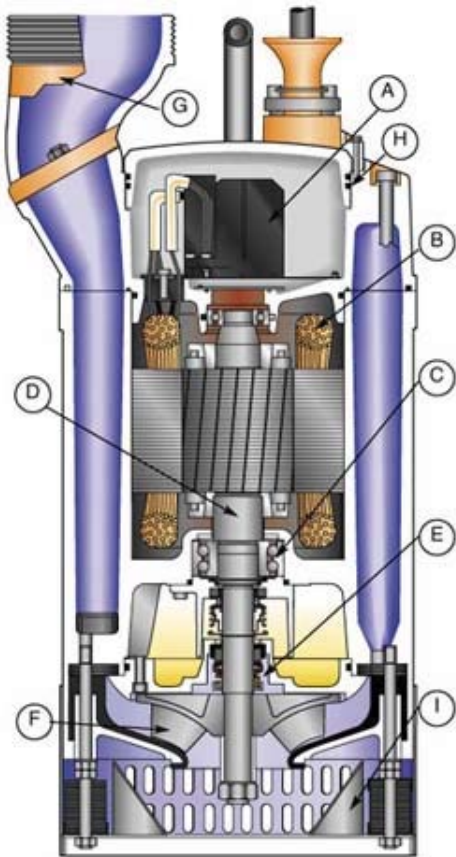

High Volume (Model S3000, 30HP Shown)

A: Junction Chamber

All Mighty dewatering pumps are equipped with a built-in contactor wired to thermal switches embedded into the end coils of the stator. In the event of motor over-heating, the contactor is tripped and automatically resets when the motor cools. All electric cables enter through a sealing gland. Water sealing and strain relief functions are separated. The entire junction chamber is sealed off from the motor to prevent burn out should moisture enter due to damage to the cable.

B: Motor

A dry, shell type, squirrel-cage induction motor is standard on all Mighty submersibles. Stator windings are triple dipped, class F Insulation, rated at 310°F (155°C). On all units pilot thermal sensors are embedded in the stator to protect the motor and exposed surfaces from overheating. All permissible and explosion proof models have especially long flame paths with very tight tolerances between all parts surrounding the motor to insure a secure housing in the event of an internal explosion.

C: Bearings

Both upper and lower bearings are prepacked with special high temperature grease.

D: Shaft

Every Mighty submersible pump is designed with a short shaft overhang. Shaft deflection due to hydraulic forces is virtually eliminated. The result is a dramatic increase in bearing and seal life. All Stancor shafts are made of stainless steel.

E: Seal

One of the most critical components of Mighty submersible pumps is the unique lapped solid silicon carbide vs. silicon carbide seals. The Mighty balanced cartridge seal will withstand heat, corrosion and abrasion no other seals could survive. This compact unit consists of a lower balanced cartridge seal and an upper spring loaded mechanical seal assembly. The seals are arranged in tandem. each operating independent of the other in an oil chamber. The oil acts as a lubricating and cooling medium for the seal faces.

F: Liquid End

Adjustable abrasion resistant stainless steel impeller and rubber lined diffuser permit optimum efficiency to be maintained despite wear. Rubber clad, easily replaceable wear parts are standard.

G: Hose Connection

The discharge outlet can be placed in the straight out position or rotated 180° aiming the hose at an angle, eliminating kinks and bends, reducing friction losses.

H: O-rings

All mating components around motor are sealed with double o-ring seals.

I: Hardware

All Mighty fasteners and strainers are made of stainless steel.

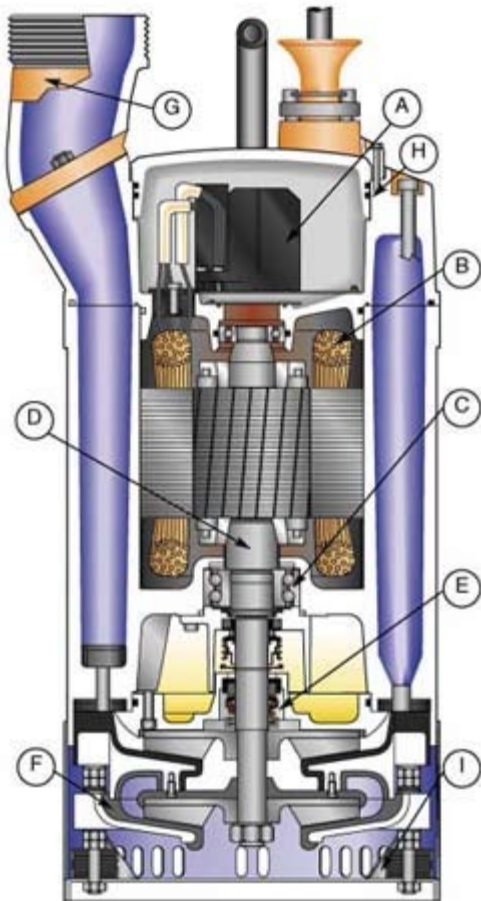

High Head (Model S3000, 30HP Shown)