

HT6 PUMP

PERFORMANCE

Maximum Outflow	1,540 US gpm (5,830 L/min)
Maximum Head	390 feet (119 m)
Solids Handling	3" (76 mm) diameter
BEP with 15' lift	1,060 US gpm @ 324 feet



PUMP FEATURES

- High Head Trash (HT) Pumps balance high lift and high volume capabilities
- Variety of pump applications including sewage, liquids, sludge and liquids with solids up to 3" (76 mm) in diameter
- Standard engine CAT C4.4 Electronic-142 hp, also available in John Deere JD4045H Electronic- 139 hp
- Stressproof™ stainless steel shaft with innovative Cycloseal® (Tungsten Carbide vs. Silicon Carbide) that increases the seal life by up to three times that of a typical mechanical seal
- Oil bath feeds the mechanical seal with cooler oil for continuous dry running
- Steel construction industrial grade, off-road trailer with automatic hydraulic brakes and an internal 99 gallon fuel tank; exempt from TDG legislation
- Protective Quiet Container is easily removable and reduces sound down to 70dB at 28ft away
- Automatic priming system that sucks air and liquid at the same time. Primes and re-primers completely unattended
- Priming system built with in-line ¼ turn isolation valve for flooded suction applications
- Auto-Start/Stop Water Level Control
- At its Best Efficiency Point this pump is 73% efficient, which reduces energy costs compared to other pumps
- Heavy duty, massive pump shafts, purposely built for industrial applications
- Optional remote monitoring with live updates that include: pump's global position, discharge pressure, engine data and maintenance log
- Warranted by Mighty Pumps, Cornell and CAT/John Deere- 2 year, 2,000 hour warranty

PERFORMANCE CURVE

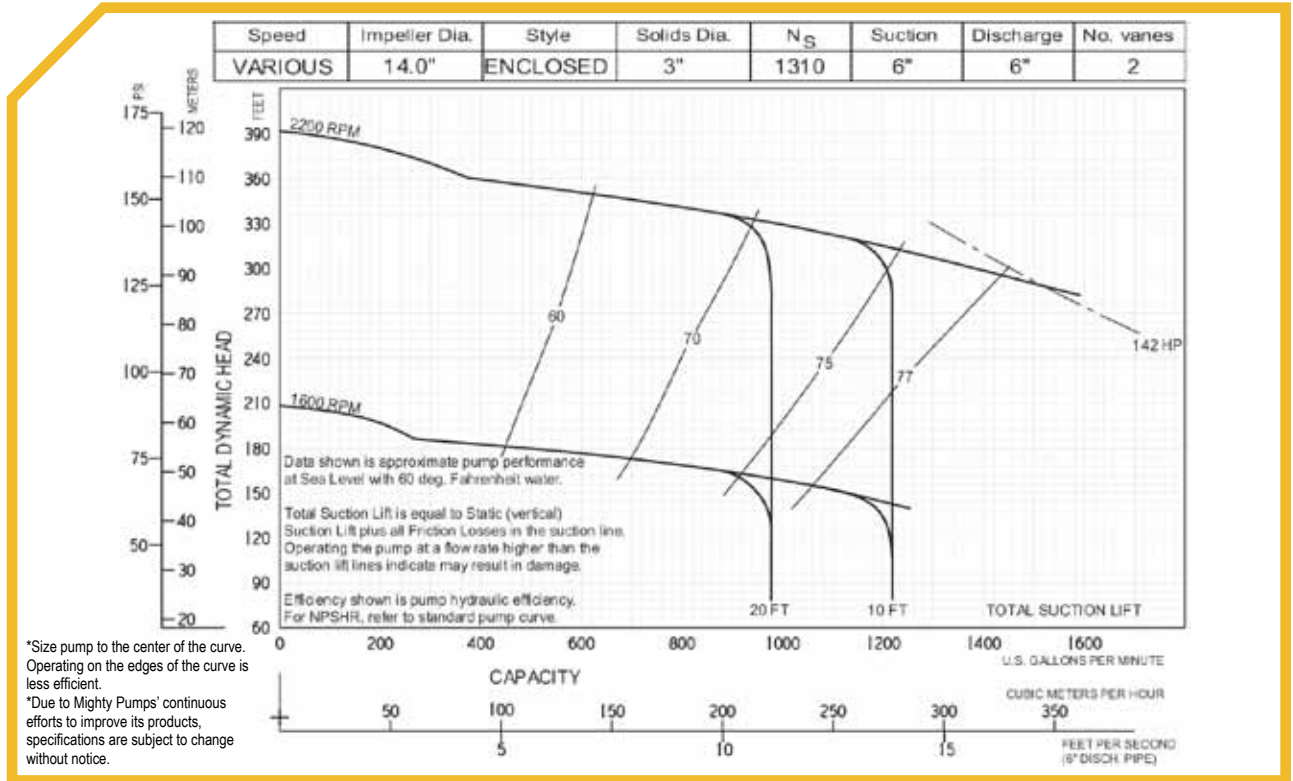

MIGHTY PUMPS™

Phone: 1-877-898-3494
 Email: sales@mightypumps.com
 www.mightypumps.com



HT6 PUMP

SPECIFICATIONS

Engine	CAT C4.4 Electronic-142 hp continuous or John Deere JD4045H Electronic- 139 hp
Pump End	Cornell 4414T
Mounting	Trailer
Sound Attenuation	Quiet Container / Residential Muffler
Fuel Tank Capacity	99 US gallons (375 L)
Fuel Consumption (1,800 rpm)	6.5 US gal/hr
Run Time* (1,800 rpm)	15 hours
Maximum Operating Speed	2,200 rpm
Max Case Pressure	150 psi (1,034 kPa)
Max Fluid Temperature	180°F (82°C)
Suction Inlet Size	6" 150 lb Flange
Discharge Outlet Size	6" 150 lb Flange

*one tank of fuel

DIMENSIONS

Height	92" (2,337 mm)
Width	72" (1,829 mm)
Length	141" (3,581 mm)
Weight (Wet)	6,159 lb (2,794 kg)

PUMP MATERIALS

Volute	ASTM A48 Cast Iron
Wear Rings	ASTM A48 Cast Iron
Backplate	ASTM A48 Cast Iron
Impeller	ASTM A48 Cast Iron
Frame	ASTM A48 Cast Iron
Trailer	CSA G40.21 350W Steel
Shaft	Stress Proof SAE 1144 Steel
Shaft Seal	Tungsten Carbide vs. Silicon Carbide
Engine Bracket	ASTM A48 Cast Iron

CORNELL 4414T

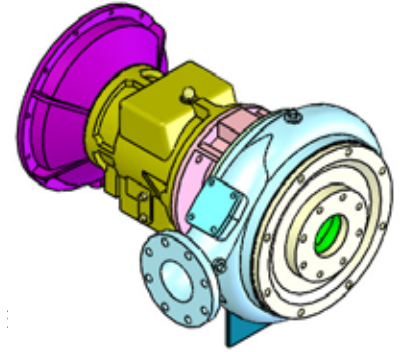

MIGHTY PUMPS FAMILY CURVE

