

# DT6 PUMP

## PERFORMANCE

<b>Maximum Outflow</b>	2,800 US gpm (10,599 L/min)
<b>Maximum Head</b>	150 feet (46 m)
<b>Solids Handling</b>	3" (76 mm) diameter
<b>BEP with 15' lift</b>	1,960 US gpm @ 85 feet



## PUMP FEATURES

- Dewatering Trash (DT) Pumps move large volumes of water
- Variety of pump applications including sewage, liquids, sludge and liquids with solids up to 3" (76 mm) in diameter
- Standard engine CAT C4.4 Mechanical-91 hp, also available in John Deere JD4045D Electronic- 74 hp
- Stressproof™ stainless steel shaft with innovative Cycloseal® (Tungsten Carbide vs. Silicon Carbide) that increases the seal life by up to three times that of a typical mechanical seal
- Oil bath feeds the mechanical seal with cooler oil for continuous dry running
- Steel construction industrial grade, off-road trailer with automatic hydraulic brakes and an internal 99 gallon fuel tank; exempt from TDG legislation
- Protective Quiet Container is easily removable and reduces sound down to 70 dB at 28ft away
- Automatic priming system that sucks air and liquid at the same time. Primes and re-primers completely unattended
- Priming system built with in-line ¼ turn isolation valve for flooded suction applications
- Auto-Start/Stop Water Level Control
- At its Best Efficiency Point this pump is 80% efficient, which reduces energy costs compared to other pumps
- Heavy duty, massive pump shafts, purposely built for industrial applications
- Optional remote monitoring with live updates that include: pump's global position, discharge pressure, engine data and maintenance log
- Warranted by Mighty Pumps, Cornell and CAT/John Deere- 2 year, 2,000 hour warranty

## PERFORMANCE CURVE

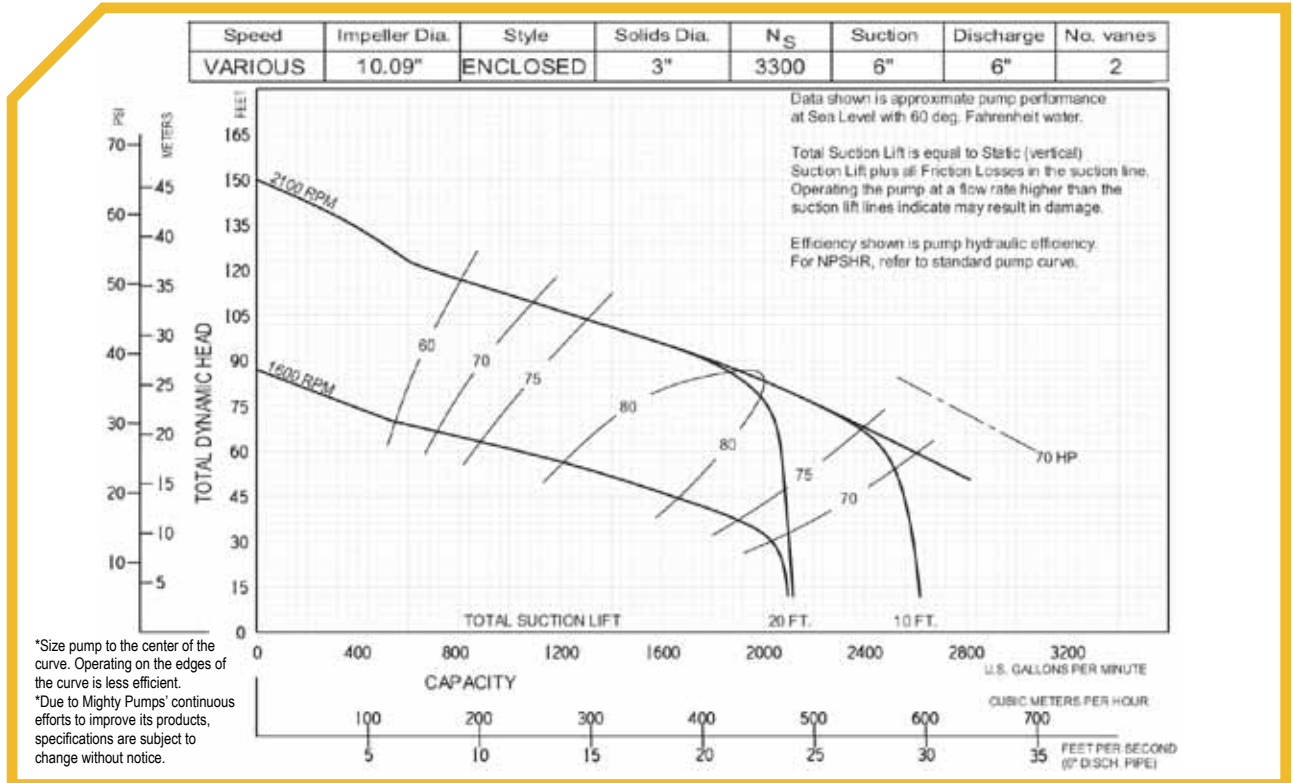

**MIGHTY PUMPS™**

Phone: 1-877-898-3494  
Email: [sales@mightypumps.com](mailto:sales@mightypumps.com)  
[www.mightypumps.com](http://www.mightypumps.com)



# DT6 PUMP

## SPECIFICATIONS

Engine	CAT CAT C4.4 Mechanical-91 hp or John Deere JD4045D Electronic- 74 hp
Pump End	Cornell 6NNT
Mounting	Trailer
Sound Attenuation	Quiet Container / Residential Muffler
Fuel Tank Capacity	99 US gallons (375 L)
Fuel Consumption (1,800 rpm)	4.3 US gal/hr
Run Time* (1,800 rpm)	23 hours
Maximum Operating Speed	2,100 rpm
Max Case Pressure	150 psi (1,034 kPa)
Max Fluid Temperature	180°F (82°C)
Suction Inlet Size	6" 150 lb Flange
Discharge Outlet Size	6" 150 lb Flange

\*one tank of fuel

## DIMENSIONS

Height	92" (2,337 mm)
Width	72" (1,829 mm)
Length	141" (3,581 mm)
Weight (Wet)	4,800 lb (2,177 kg)

## PUMP MATERIALS

Volute	ASTM A48 Cast Iron
Wear Rings	ASTM A48 Cast Iron
Backplate	ASTM A48 Cast Iron
Impeller	ASTM A48 Cast Iron
Frame	ASTM A48 Cast Iron
Trailer	CSA G40.21 350W Steel
Shaft	Stress Proof SAE 1144 Steel
Shaft Seal	Tungsten Carbide vs. Silicon Carbide
Engine Bracket	ASTM A48 Cast Iron

## CORNELL 6NNT

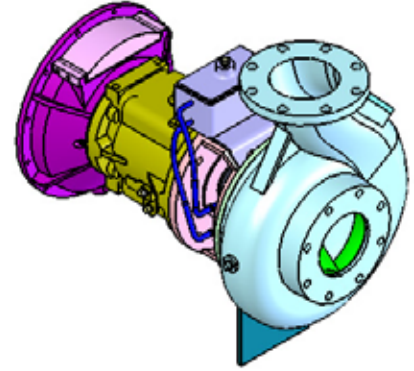

## MIGHTY PUMPS FAMILY CURVE

