

DT24 PUMP

PERFORMANCE

Maximum Outflow	33,400 US gpm (126,433 L/min)
Maximum Head	135 feet (41 m)
Solids Handling	5.25" (133 mm) diameter
BEP with 15' lift	22,800 US gpm @ 100 feet



PUMP FEATURES

- Dewatering Trash (DT) Pumps move large volumes of water
- Variety of pump applications including sewage, liquids, sludge and liquids with solids up to 5.25" (133 mm) in diameter
- Standard engine CAT C27-875 hp
- Stressproof™ stainless steel shaft with innovative Cycloseal® (Tungsten Carbide vs. Silicon Carbide) that increases the seal life by up to three times that of a typical mechanical seal
- Oil bath feeds the mechanical seal with cooler oil for continuous dry running
- Steel construction skid
- Capable of remote monitoring for live updates that include: pump's global position, discharge pressure, engine data and maintenance log
- Automatic Priming System sucks air and liquid at the same time. Primes and re-primers completely unattended
- Priming system built with in-line ¼ turn isolation valve for flooded suction applications
- At its Best Efficiency Point this pump is 85% efficient, which reduces energy costs compared to other pumps
- Heavy duty, massive pump shafts, purposely built for industrial applications
- Optional Water Level Control
- Optional, easily removable protective Quiet Container that reduces sound down to 70 dB at 28ft away
- Warranted by Mighty Pumps, Cornell and CAT- 2 year, 2,000 hour warranty

PERFORMANCE CURVE

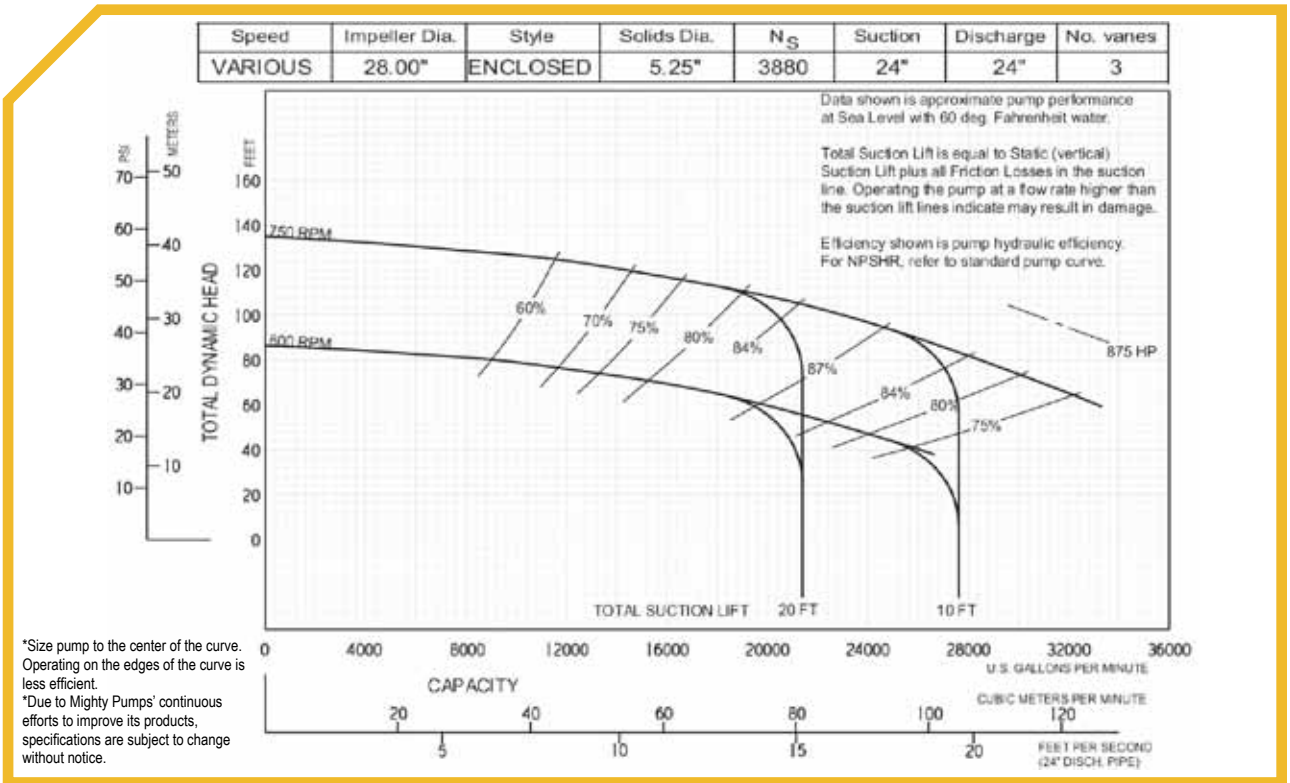

DT24 PUMP

SPECIFICATIONS

Engine	CAT C27-875 hp continuous
Pump End	Cornell 24NNG
Gear Box	Twin Disc MG-5114SC-HD
Mounting	Skid
Fuel Tank Capacity	400 US gallons (1,514 L)
Fuel Consumption (1,800 rpm)	40.8 US gal/hr
Run Time* (1,800 rpm)	10 hours
Maximum Operating Speed	750 rpm
Max Case Pressure	150 psi (1,034 kPa)
Max Fluid Temperature	180°F (82°C)
Suction Inlet Size	24" 150 lb Flange
Discharge Outlet Size	24" 150 lb Flange

*one tank of fuel

DIMENSIONS

Height	112" (2,845 mm)
Width	88" (2,235 mm)
Length	262" (6,655 mm)
Weight (Wet)	34,452 lb (15,627 kg)

PUMP MATERIALS

Volute	ASTM A48 Cast Iron
Wear Rings	ASTM A48 Cast Iron
Backplate	ASTM A536-72 Ductile Iron
Impeller	ASTM A48 Cast Iron
Frame	ASTM A48 Cast Iron
Shaft	Stress Proof SAE 1144 Steel
Shaft Seal	Tungsten Carbide vs. Silicon Carbide
Engine Bracket	ASTM A48 Cast Iron
Skid	CSA G40.21 44W Steel

CORNELL 24NNG

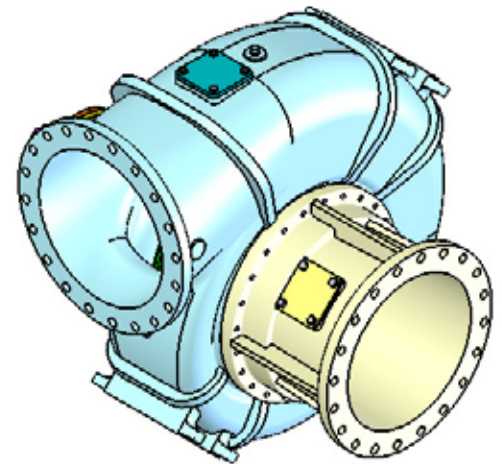

MIGHTY PUMPS FAMILY CURVE

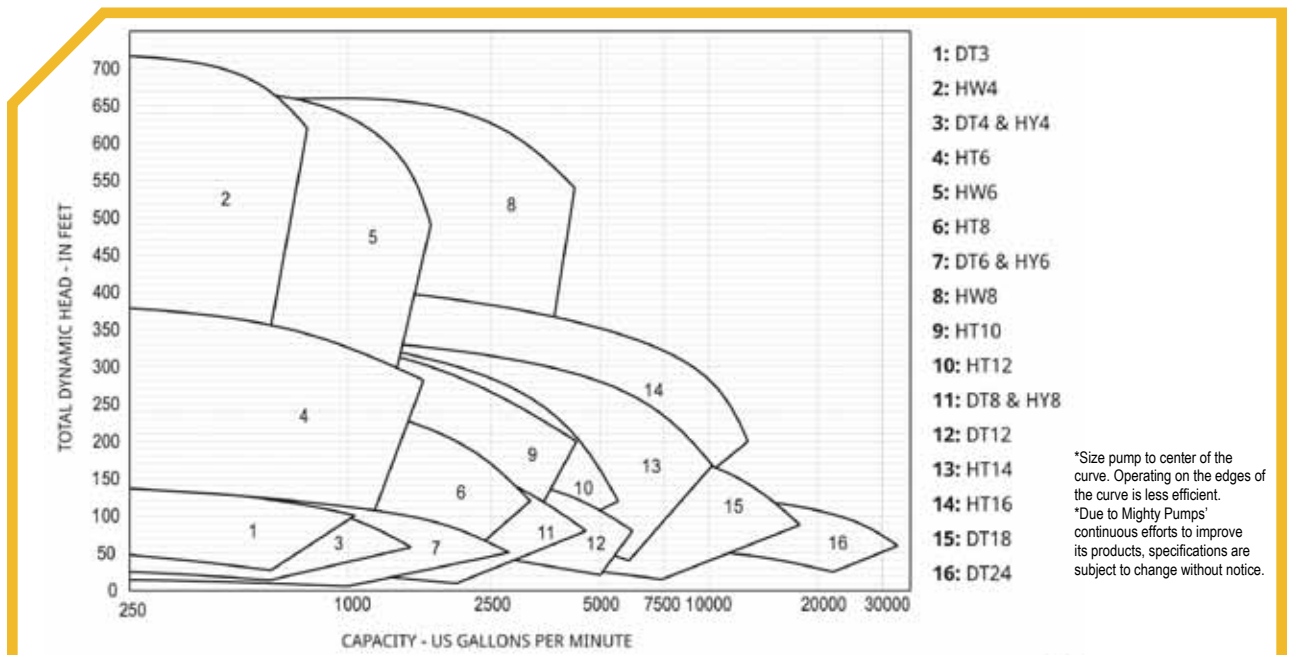

INDUSTRIAL STRENGTH
QUIET
EFFICIENT
JET-PRIME



MIGHTY PUMPS™

Phone: 1-877-898-3494
 Email: sales@mightypumps.com
 www.mightypumps.com

