

HT16 PUMP

PERFORMANCE

Maximum Outflow	12,800 US gpm (48,453 L/min)
Maximum Head	410 feet (125 m)
Solids Handling	3.2" (81 mm) diameter
BEP with 15' lift	7,000 US gpm @ 335 feet



PUMP FEATURES

- High Head Trash (HT) Pumps balance high lift and high volume capabilities
- Variety of pump applications including sewage, liquids, sludge and liquids with solids up to 3.2" (81 mm) in diameter
- Standard engine CAT C32-950 hp
- Stressproof™ stainless steel shaft with innovative Cycloseal® (Tungsten Carbide vs. Silicon Carbide) that increases the seal life by up to three times that of a typical mechanical seal
- Oil bath feeds the mechanical seal with cooler oil for continuous dry running
- Steel construction skid. Also available with an industrial grade, off-road trailer mount
- Capable of remote monitoring with live updates that include: pump's global position, discharge pressure, engine data and maintenance log
- Automatic Priming System sucks air and liquid at the same time. Primes and re-primers completely unattended
- Priming system built with in-line ¼ turn isolation valve for flooded suction applications
- At its Best Efficiency Point this pump is 82% efficient, which reduces energy costs compared to other pumps
- Heavy duty, massive pump shafts, purposely built for industrial applications
- Optional Water Level Control
- Optional, easily removable protective Quiet Container that reduces sound down to 70 dB at 28ft away
- Warranted by Mighty Pumps, Cornell and CAT- 2 year, 2,000 hour warranty

PERFORMANCE CURVE

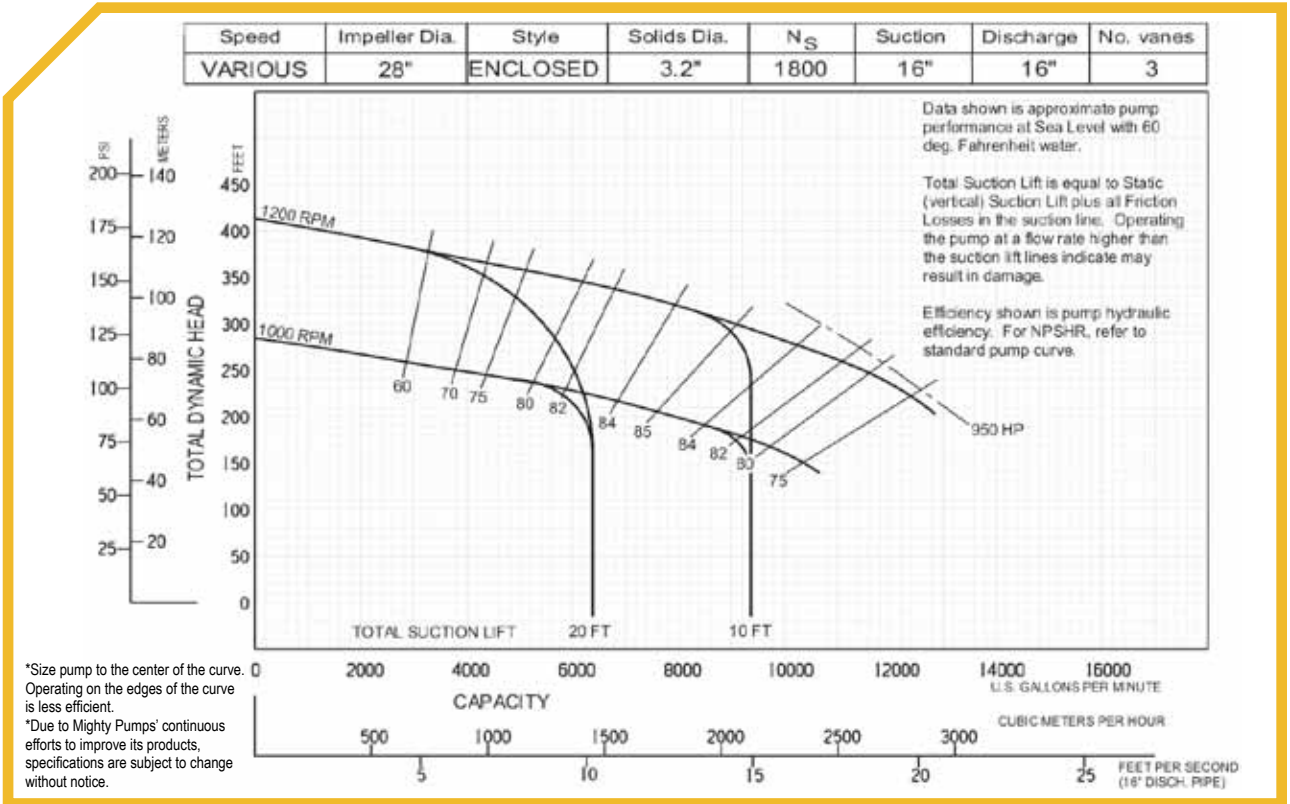

HT16 PUMP

SPECIFICATIONS

Engine	CAT C32-950 hp continuous
Pump End	Cornell 12NHG28
Gear Box	Twin Disc MG-5114SC-HD
Mounting	Skid
Fuel Tank Capacity	400 US gallons (1,514 L)
Fuel Consumption (1,800 rpm)	45.7 US gal/hr
Run Time* (1,800 rpm)	9 hours
Maximum Operating Speed	1,200 rpm
Max Case Pressure	200 psi (1,379 kPa)
Max Fluid Temperature	180°F (82°C)
Suction Inlet Size	16" 150 lb Flange
Discharge Outlet Size	16" 150 lb Flange

*one tank of fuel

DIMENSIONS

Height	112" (2,845 mm)
Width	81" (2,057 mm)
Length	227" (5,766 mm)
Weight (Wet)	26,602 lb (12,067 kg)

PUMP MATERIALS

Volute	ASTM A536-72 Ductile Iron
Wear Rings	ASTM A48 Cast Iron
Backplate	ASTM A536-72 Ductile Iron
Impeller	ASTM A48 Cast Iron
Frame	ASTM A48 Cast Iron
Shaft	Stress Proof SAE 1144 Steel
Shaft Seal	Tungsten Carbide vs. Silicon Carbide
Engine Bracket	ASTM A48 Cast Iron
Skid	CSA G40.21 44W Steel

CORNELL 12NHG28

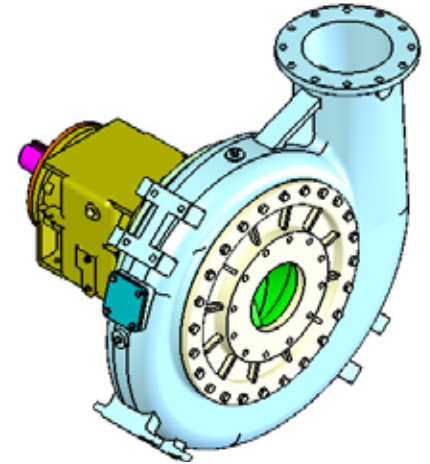

MIGHTY PUMPS FAMILY CURVE

